

EDBEMV82EV
00475775

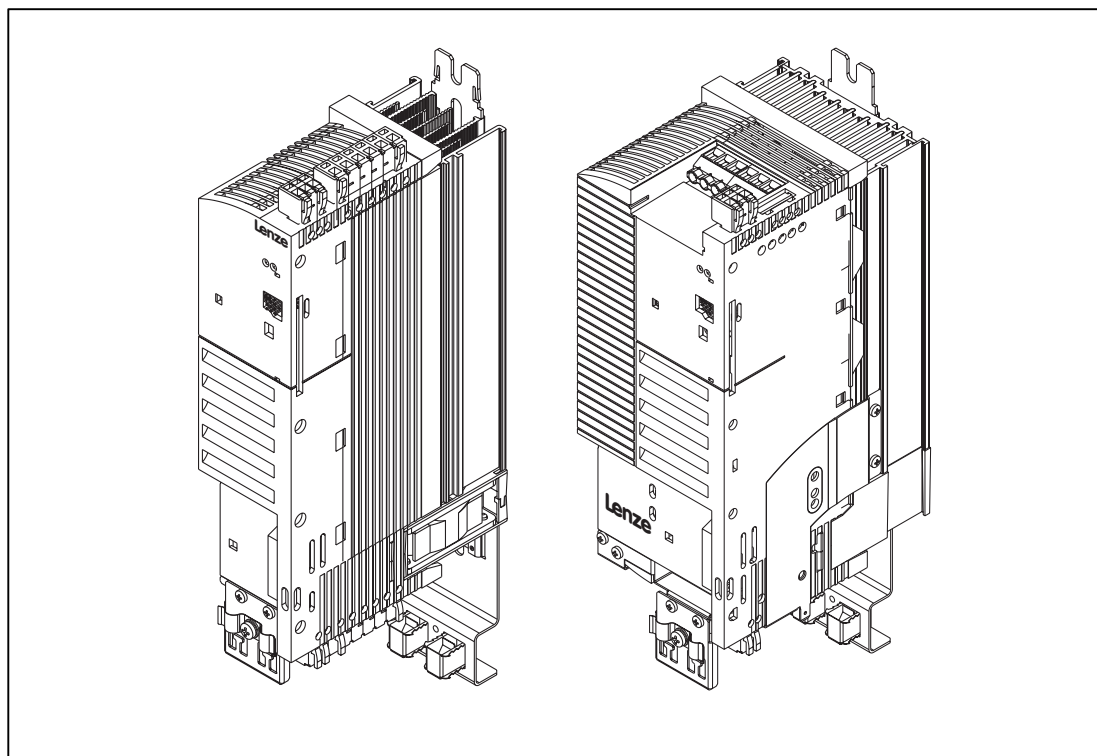

Lenze

Wiring according to EMC requirements



Global Drive
Frequency inverters
8200 vector series
0.25 kW ... 11 kW

This documentation is only valid for 8200 vector controllers as of version:

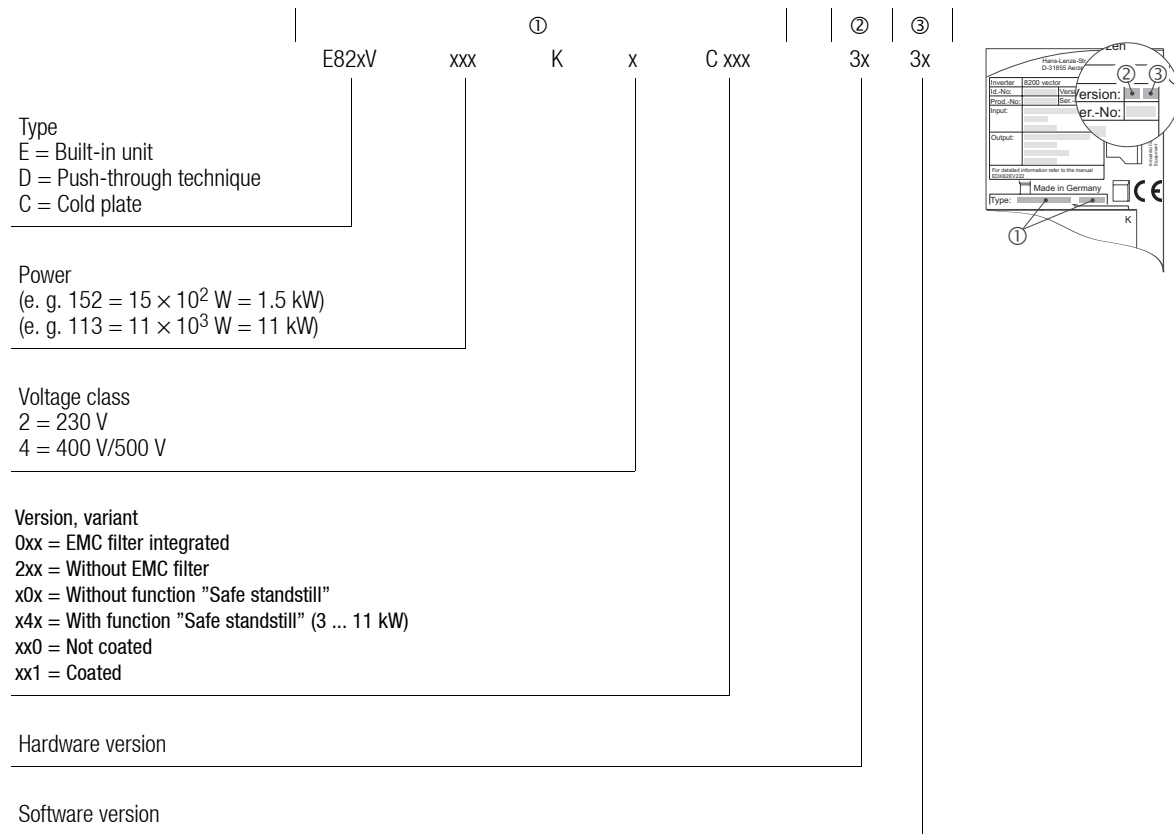

© 2003 Lenze Drive Systems GmbH

Without written approval of Lenze Drive Systems GmbH no part of these Instructions must be copied or given to third parties.

All information given in this documentation has been selected carefully and comply with the hardware and software described. Nevertheless, deviations cannot be ruled out. We do not take any responsibility or liability for damages which might possibly occur. We will include necessary corrections in subsequent editions.

Version

3.0

10/2003

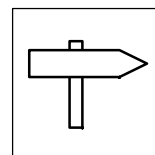

1	Preface	2
1.1	About these Instructions	2
1.2	Terminology used	2
2	Safety instructions	4
2.1	Safety and application notes for Lenze controllers	4
2.3	Residual hazards	7
2.4	Layout of the safety instructions	8
3	Wiring according to EMC (structure of a CE-typical drive system)	9
3.1	Basic rules	9
3.1.1	Installation in the control cabinet	10
3.1.2	Specification of the cables used	10
3.1.3	Shield connection	10
3.1.4	Earthing	11
3.1.5	Wiring on the mains side	11
3.1.6	Wiring on the motor side	12
3.2	Power connections	14
3.2.1	230 V mains	15
3.2.2	400 V mains	18
3.3	Control connections	20
3.3.1	Basic rules for wiring	20
3.4	Relay output	21
3.4.1	Basic rules for wiring	21
3.4.2	Wiring	21
3.5	PTC input	22
3.5.1	Basic rules for wiring	22
3.5.2	Wiring	22
3.6	Accessories	23
3.6.1	Mains choke	23
3.6.2	Brake resistor	24
3.6.3	DC-bus system	25
4	Recognising and eliminating EMC interferences	26

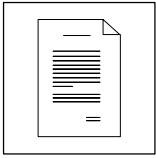

Preface and general information

1 Preface

Based on the brochure "EMC basic information" this second part "Wiring according to EMC requirements" informs the user of the 8200 vector series about the application of the basic devices and accessories according to EMC requirements.

The Lenze accessories for 8200 vector series comprises many components which are relevant with regard to EMC.

The following components are included in the accessories:

- Mains chokes
- RFI filters
- Motor interference modules
- Motor filters

The assignment and mode of operation of these EMC components are described in detail.

1.1 About these Instructions

- These Instructions are intended for all persons who design and install the 8200 vector frequency inverters.
- These Instructions describe the structure of a CE-typical drive system with the 8200 vector frequency inverter. If you follow the instructions you can assume that
 - the 8200 vector frequency inverters comply with the standards "Electromagnetic compatibility (EMC)".
 - the operation with 8200 vector frequency inverters will be free of any EMC interferences.

1.2 Terminology used

Term	In the following text used for
Controller	Any Lenze frequency inverter, Lenze servo inverter or Lenze DC controller
vector	8200 vector frequency inverter
Drive	Lenze controller in combination with a geared motor, a three-phase AC motor or other Lenze drive components.
AIF	Automation InterFace: Interface for a communication module.
FIF	Function InterFace: Interface for a function module.
Cxxxx/y	Subcode y of code Cxxxx (e. g. C0410/3 = subcode 3 of code C0410)
Xk/y	Terminal y on terminal strip Xk (e. g. X3/28 = terminal 28 on terminal strip X3)
 xx-yyy	Cross reference to a page

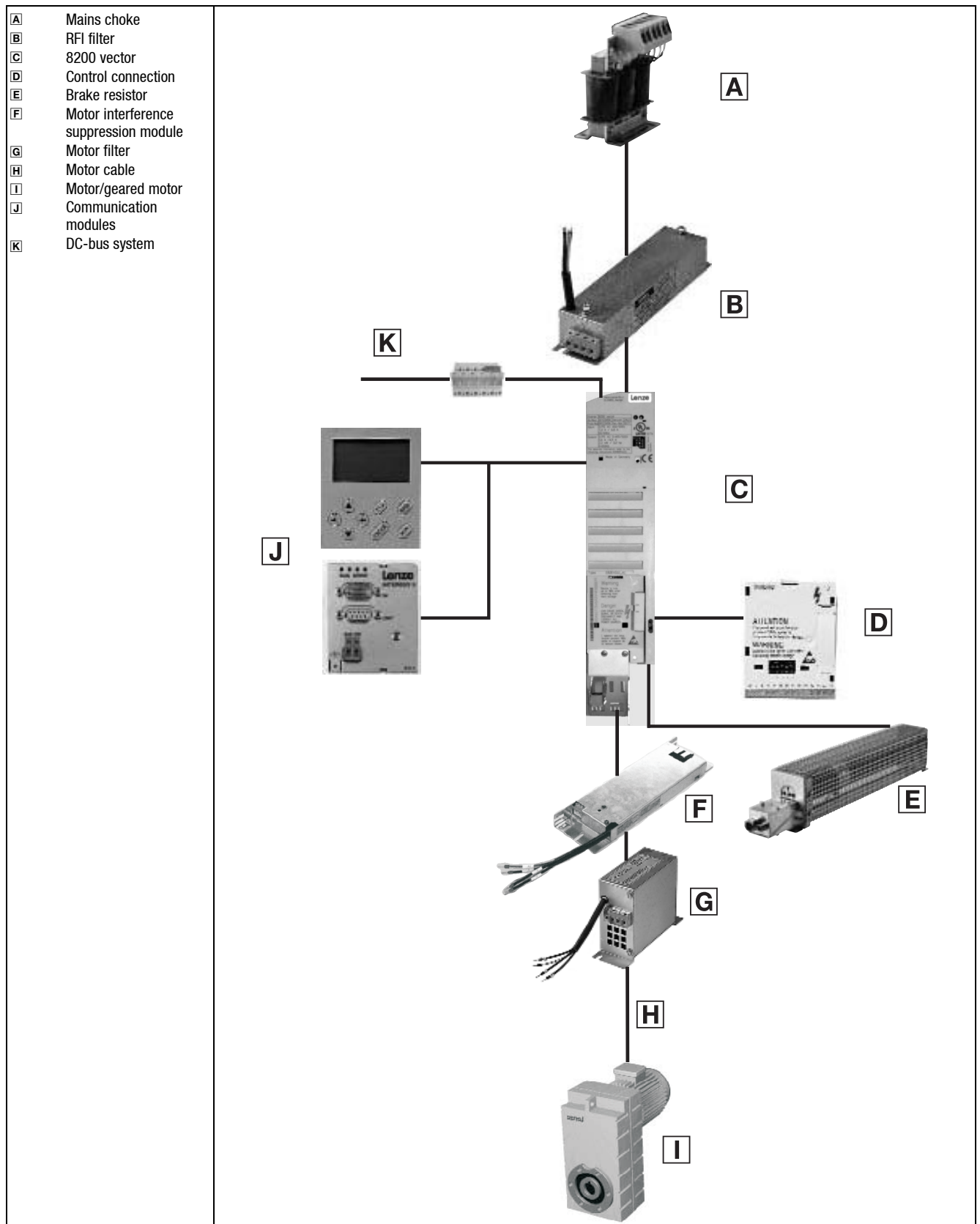
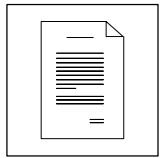

Fig. 1 Components of the drive system



Safety information

Lenze controllers

2 Safety instructions

2.1 Safety and application notes for Lenze controllers

(in conformity with the Low-Voltage Directive 73/23/EEC)

General

Lenze controllers (frequency inverters, servo inverters, DC controllers) can include live and rotating parts - depending on their type of protection - during operation. Surfaces can be hot.

Non-authorized removal of the required cover, inappropriate use, incorrect installation or operation, creates the risk of severe injury to persons or damage to material assets.

For more detailed information please see the documentation.

All operations concerning transport, installation, and commissioning as well as maintenance must be carried out by qualified, skilled personnel (IEC 364 or CENELEC HD 384 or DIN VDE 0100 and IEC report 664 or DIN VDE 0110 and national regulations for the prevention of accidents must be observed).

According to this basic safety information qualified skilled personnel are persons who are familiar with the installation, assembly, commissioning, and operation of the product and who have the qualifications necessary for their occupation.

Application as directed

Drive controllers are components which are designed for installation in electrical systems or machinery. They are not to be used as household appliances. They are intended exclusively for professional and commercial purposes according to EN 61000-3-2. This documentation includes information in compliance with the EN 61000-3-2.

When installing the drive controllers in machines, commissioning (i.e. starting of operation as directed) is prohibited until it is proven that the machine complies with the regulations of the EC Directive 98/37/EC (Machinery Directive); EN 60204 must be observed.

Commissioning (i.e. starting of operation as directed) is only allowed when there is compliance with the EMC Directive (89/336/EEC).

The drive controllers meet the requirements of the Low-Voltage Directive 73/23/EEC. The harmonised standards of the series EN 50178/DIN VDE 0160 apply to the controllers.

The technical data and information on the connection conditions must be obtained from the nameplate and the documentation. They must be observed in any case.

Warning: The availability of controllers is restricted according to EN 61800-3. These products can cause radio interferences in residential areas. In this case, special measures are required.

Transport, storage

Please observe the notes on transport, storage and appropriate handling.

Observe the climatic conditions according to EN 50178.



Installation

The controllers must be installed and cooled according to the regulations given in the documentation.

Ensure proper handling and avoid mechanical stress. Do not bend any components and do not change any insulation distances during transport or handling. Do not touch any electronic components and contacts.

Controllers contain electrostatically sensitive components which can easily be damaged by inappropriate handling. Do not damage or destroy any electrical components since this might endanger your health!

Electrical connection

When working on live drive controllers, the applicable national regulations for the prevention of accidents (e.g. VBG 4) must be observed.

The electrical installation must be carried out according to the appropriate regulations (e.g. cable cross-sections, fuses, PE connection). Additional information can be obtained from the documentation.

The documentation contains information about installation in compliance with EMC (shielding, grounding, filters and cables). These notes must also be observed for CE-marked controllers. The manufacturer of the system or machine is responsible for the compliance with the required limit values demanded by the EMC legislation.

Operation

Systems including controllers must be equipped with additional monitoring and protection devices according to the corresponding standards (e.g. technical equipment, regulations for the prevention of accidents, etc.). If necessary, adapt the controllers to your application. Please observe the corresponding information given in the Instructions.

After the controller has been disconnected from the supply voltage, live components and power connection must not be touched immediately since capacitors could be charged. Please observe the corresponding notes on the controller.

All covers and doors must be closed during operation.

Note for UL-approved systems with integrated controllers: UL warnings are notes which apply to UL systems. The documentation contains special information about UL.

Safe standstill

Variant V004 of the controller series 9300 and 9300 vector, variant x4x of the controller series 8200 vector and axis module ECSxAxxx support the function "Safe standstill", protection against unintentional restart, according to the requirements of Appendix I, No. 1.2.7 of the EC Directive "Machinery" 98/37/EC, DIN EN 954-1 category 3 and DIN EN 1037. It is absolutely necessary to observe the information about the function "Safe standstill" in the corresponding documentation and instructions.

Maintenance and servicing

The controllers do not require any maintenance, if the application conditions prescribed are observed.

In operating areas with polluted ambient air, the cooling surfaces of the controller can get dirty or the cooling openings can block. Under these conditions a regular cleaning of the cooling surfaces and cooling openings is essential. Do not use sharp or pointed objects for this purpose!



Safety information

Lenze controllers

Disposal

Recycle metals and plastics. Dispose of printed circuit board assemblies according to the state of the art.

The product-specific safety and application notes in these Instructions must also be observed!

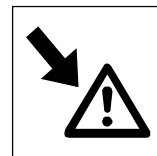

2.2 Residual hazards

Protection of persons

- Before working on the controller check that no voltage is applied to the power terminals, the relay output and the pins of the FIF interface,
 - because the power terminals U, V, W, +UG, -UG, BR1 and BR2 remain live for at least 3 minutes after mains switch-off.
 - because the power terminals L1, L2, L3; U, V, W, +UG, -UG, BR1 and BR2 remain live when the motor is stopped.
 - because the relay outputs K11, K12, K14 can remain live when the controller is disconnected from the mains.
- If you use the non-fail safe function "Selection of direction of rotation" via the digital signal DCTRL1-CW/CCW (C0007 = 0 ... 13, C0410/3 ≠ 255):
 - In the event of an open circuit or failure of the control voltage, the drive can change its direction of rotation.
- If you use the function "Flying-restart circuit" (C0142 = 2, 3) with machines with a low moment of inertia and a minimum friction:
 - After controller enable in standstill, the motor can start for a short time or change its direction of rotation for a short time.
- The heatsink of the controller has an operating temperature of > 80°C:
 - Direct skin contact with the heatsink results in burnings.

Controller protection

- All pluggable connection terminals must only be connected or disconnected when no voltage is applied!
- **Cyclic** connection and disconnection of the supply voltage can overload and destroy the input current limitation of the controller:
 - In case of cyclic mains switching over a longer period of time three minutes have to pass between two starting operations!

Motor protection

- Depending on the controller settings, the connected motor can be overheated:
 - For instance, longer DC-braking operations.
 - Longer operation of self-ventilated motors at low speed.

Controller/system protection

- Drives can reach dangerous overspeeds (e.g. setting of inappropriately high field frequencies):
 - The controllers do not offer any protection against these operating conditions. For this, use additional components.







Safety information

Residual hazards, Layout of the safety instructions

2.3 Layout of the safety instructions

All safety information given in these Instructions have got the same layout:

 Pictograph (indicates the type of danger)
Signal word! (indicates the severity of danger)
 Note (describes the danger and explains how to avoid it)

Pictograph	Signal word	Signal word	Possible consequences if the safety information is disregarded
		Meaning	
 Dangerous electrical voltage  General danger	Danger!	Impending danger for persons	Death or most severe injuries
	Warning!	Possible, very dangerous situation for persons	Death or most severe injuries
	Caution!	Possible, dangerous situation for persons	Injuries
	Stop!	Possible material damage	Damage of the drive system or its surroundings
	Note!	Useful note or tip If you observe it, handling of the drive system will be easier.	

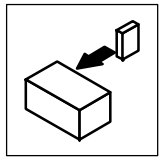

3 Wiring according to EMC (structure of a CE-typical drive system)

3.1 Basic rules

The structure of a CE-typical drive system will be more efficient by means of wiring according to EMC. Wiring according to EMC is determined by the type of installation and the care taken.

Figure 2 shows two important rules for installation:

- careful structure
- good shielding
- good earthing
- separated cable routing

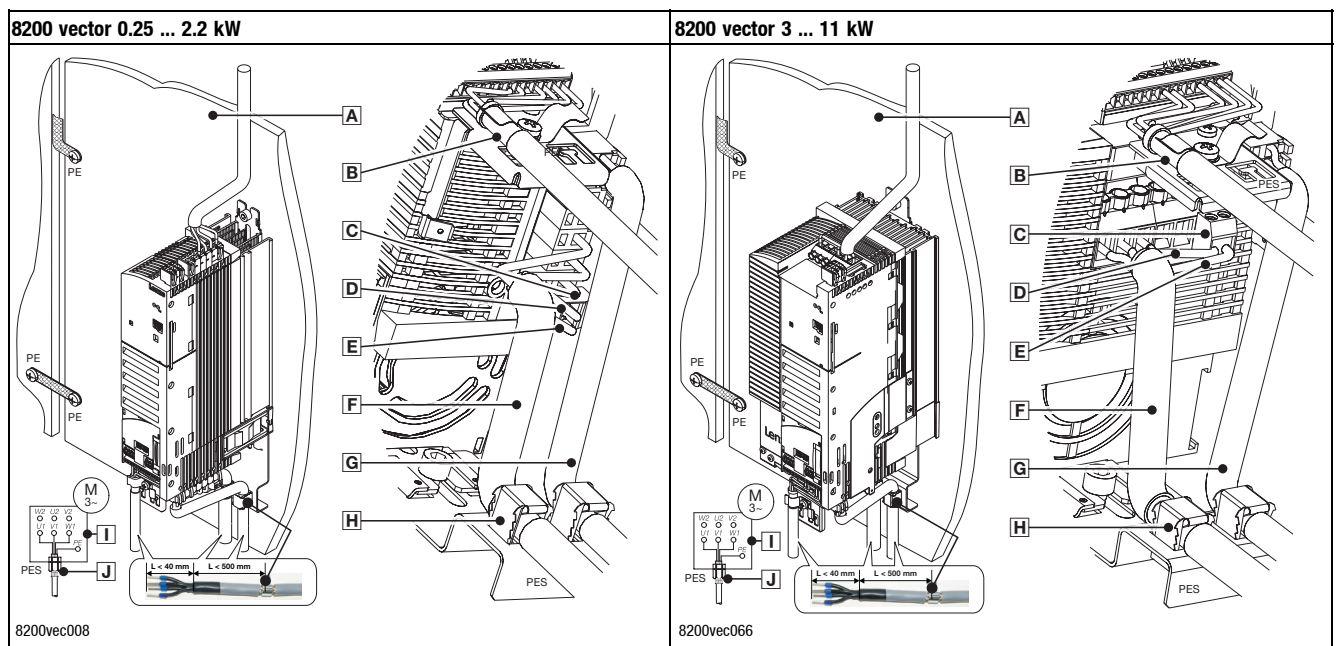
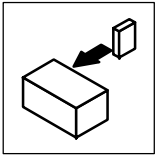

Fig. 2

Installation principle according to EMC

- A** Mounting plate with electrically conductive surface
- B** Control cable to function module, connect the shielding to the EMC shield sheet (PES) with a surface as large as possible
- C** 2-pole terminal for motor PE and motor shield
- D** PE of the motor cable
- E** Shield of the motor cable
- F** Shielded low-capacitance motor cable
(Core/core $1.5 \text{ mm}^2 \leq 75 \text{ pF/m}$; from $2.5 \text{ mm}^2 \leq 100 \text{ pF/m}$; core/shield $\leq 150 \text{ pF/m}$)
- G** Shielded PTC cable or thermal contact cable
- H** Connect the cable shields to the EMC shield sheet (PES) with a large surface. Use the enclosed shield clamps.
- I** Star or delta connection as indicated on the motor nameplate
- J** EMC cable gland (not included in the scope of supply)



Wiring according to EMC

Always observe these basic rules

3.1.1 Installation in the control cabinet

The mounting plate ^A

- Use mounting plates with an electrically conductive surface (zinc-coated or V2A).
- Varnished mounting plates are not suitable even if the varnish on the contact areas is removed. The contact areas without varnish bear the risk of rust formation.
- If the installation is distributed among several mounting plates, the mounting plates must be electrically connected with a surface as large as possible (e.g. with earthing strips).

Mounting of the components

- Connect the controller and RFI filter to the earthed mounting plate with a surface as large as possible.
- DIN rail mounting is not suitable!

Correct cable installation

- Control cables and mains cables must be separated from the motor cable.
- Cross the motor cable at right angles with mains cables and control cables.
- Optimally the motor cable is installed without interruptions.
- Install terminals for the motor cables e.g. at the control cabinet entry with a minimum distance from the other terminals of at least 100 mm.
- The cables must always be installed close to the mounting plate (reference potential), as loose cables act like aerials.
- Install mains cables and control cables in separate cable ducts.
- Connect shielded cable sections with the reference potential.

3.1.2 Specification of the cables used

- The cables used must comply with the requirements of the application (e.g. UL, EN 60204-1).
- Only use shielded cables with a braid made of tinned or nickel-plated copper. Do not use braids made of steel.
- The overlap rate of the braid must amount to at least 70 % with an overlap angle of 90°.

3.1.3 Shield connection

- Connect the shields with a large surface to the EMC shield sheet on the device side.
- Do not disconnect the shield after the contact area but continue it up to the terminals.

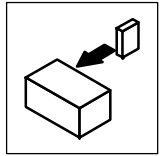

3.1.4 Earthing

- Connect all components (controller, RFI filter, filter, chokes) to a central earthing point (PE rail).
- Set up a star-shape earthing system.
- Comply with the corresponding minimum cable cross-sections.

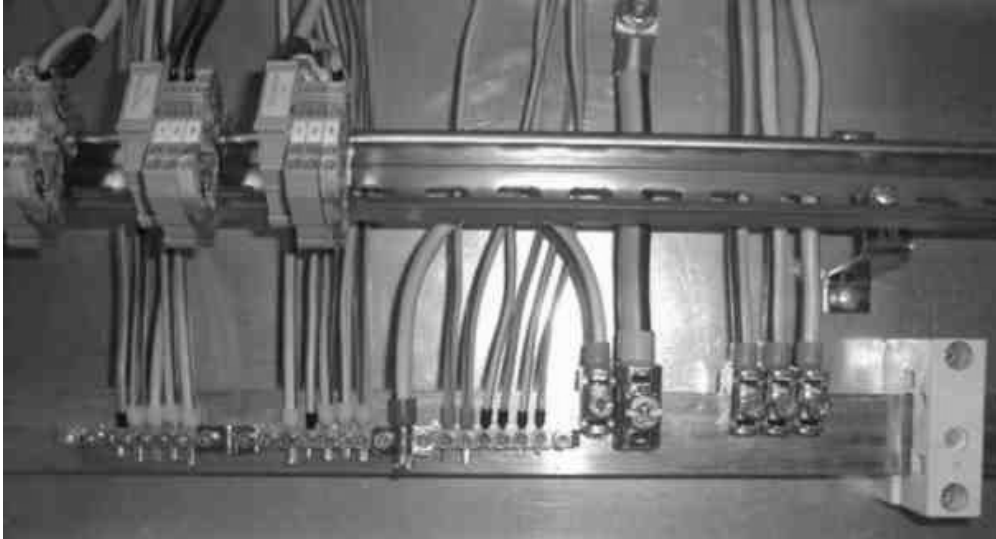
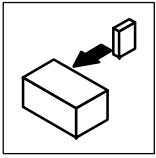

Fig. 3 star-shaped earthing system

3.1.5 Wiring on the mains side

- For mains connection of the mains choke or the RFI filter to the controller single cores or unshielded cables with a length of up to 300 mm are suitable.
- If the connecting cable between mains choke and controller is longer than 300 mm,
 - a shielded connecting cable is required.
 - connect this shield directly at the controller and the mains choke to the mounting plate with a surface as large as possible.
- The cable cross-section must be rated for the assigned fuse protection (EN 50178).



Wiring according to EMC

Always observe these basic rules

3.1.6 Wiring on the motor side

Measures for suppressing the interfering radiation depend on the length and design of the motor cable. The following table provides an overview of the required RFI measures:

Radio interference suppression

	Motor cable length					
	shielded				unshielded ¹⁾	
	up to 50 m		50 ... 100 m ²⁾		up to 100 m	100 ... 200 m ²⁾
	Continuous shield	Interrupted shield	Continuous shield	Interrupted shield		
RFI filter	✓	✓	✓	✓	✓	✓
Motor filter	—	—	✓	✓	—	✓
Motor interference suppression module	—	(✓)	—	(✓)	(✓)	(✓)

✓ Measure is required

(✓) Check measure in case of EMC interferences

1) Interfering radiation is not considered

2) Operation is only permissible with a switching frequency of 8 kHz, U/f characteristic control, maximum output frequency 480 Hz



Note!

The motor cable is highly susceptible to interferences. Hence the following applies:

The motor cable must **not** contain any further cables (e.g. for brake control, separate fans etc.).

One exception is the temperature monitoring cable of the motor.

Comply with the specification of the motor cable

- Use shielded low-capacitance motor cables only:

Requirements on the motor cable capacitance

	Cable cross-section					
	mm ²	1	1.5	2.5	4	6
Capacitance per unit length	AWG	18	16	12	10	10
Core/core	[pF/m]	< 75			< 100	
Core/shield	[pF/m]	< 150				

- The motor must be designed for a rated voltage of > 500 V AC (test voltage 2 kV AC).
- The maximum permissible motor cable length amounts to 50 m without external measures (e.g. motor filter)

Connect the shield of the motor cable correctly

Always connect the motor cable shield to both sides - controller and motor.

- Shield connection to the controller/control cabinet
 - Connect the shield with a large surface to the EMC shield sheet using a shield clamp.
 - For this purpose use the enclosed shield clamp.
 - Continue the shield after the shield clamp to the terminals of the inverter or the clamping point. Do not exceed an unshielded cable length of 40 mm.
 - In addition, it is recommended to connect the shield to PE (see ☐ in Fig. 2).
- Shield connection at the motor
 - Connect the shield at the motor terminal box with EMC cable glands.

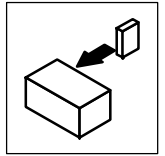

If at all possible do not rip open the motor cable

Cuts in the motor cable due to contactors or switches are potential interfering radiators since the motor cable shield is interrupted. For this reason please avoid to rip open the motor cable.

If it is indispensable to rip open the motor cable, the following must be observed:

- Connect the shield directly before and behind the cut to the mounting plate with a surface as large as possible. Do not exceed an unshielded cable length of max. 40 mm.
- Install the cut points with a distance of at least 100 m to the other components on the mounting plate.
- If EMC interferences occur check whether an additional motor interference suppression module is required.

Assignment table of motor interference suppression module

Motor interference suppression module		Application with 8200 vector
Type	U _N [V]	Type
E82ZM37132B002	240	E82xV251K2 E82xV371K2
E82ZM75134B004	400	E82xV551Kx E82xV751Kx
E82ZM22234B004		E82xV152Kx E82xV222Kx
E82ZM11334B004		E82xV302Kx E82xV402Kx E82xV552Kx E82xV752Kx E82xV113K4
E82ZM75134B005	500	E82xV551K4 E82xV751K4
E82ZM22234B005		E82xV152K4 E82xV222K4
E82ZM11334B005		E82xV302K4 E82xV402K4 E82xV552K4 E82xV752K4 E82xV113K4

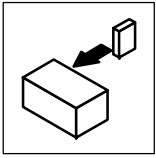

Wiring according to EMC

Power connections

3.2 Power connections

There are two options for radio interference suppression of the 8200 vector frequency inverter:

8200 vector frequency inverter with integrated RFI filter (types E82xVxxxKxC0xx)

- Compliance with the limit classes A and B according to EN 55011 without additional measures.
- The permissible motor cable length depends on the limit class to be observed, which 8200 vector type is used, and the switching frequency (type-specific data on demand).

8200 vector frequency inverter without integrated RFI filter (types E82xVxxxKxC2xx)

- Compliance with the limit classes A and B according to EN 55011 with footprint RFI filter for long motor cables. The RFI filters are designed so that they can be mounted directly below the 8200 vector frequency inverter. The footprint RFI filters also enable the frequency inverters to be mounted side by side.

You can choose from two different filter types:

- For motor cables up to 20 m: RFI filter SD (Short Distance).
 - RFI filters SD are additionally specified for being operated on a 30 mA earth-leakage circuit breaker.
- For motor cables from 20 m to 50 m: RFI filter LD (Long Distance).
- For motor cables from 50 m to 100 m the RFI filter LD is combined with a motor filter.

Limitation of harmonic currents

The European Standard EN 61000-3-2 determines limit values for limiting harmonic currents in the supply system. Non-linear loads (e.g. frequency inverters) produce harmonic currents which may have an influence on the supply system and thus interfere with other loads. The Standard wants to secure the quality of the public supply system and reduce the mains load.

Note: The Standard only applies to public mains and electrical equipment < 1 kW power or electrical equipment with a mains current of up to max. 16 A:

Mains systems which have their own transformer station as common in industry are not public. The Standard does not apply to them.

If the electrical equipment consists of several components (e.g. 8200 vector), the total unit must comply with the limit values defined in the Standard. Further information is given in the chapters 3.2.1.2 and 3.2.2.2.

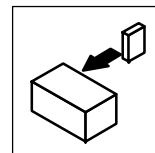

3.2.1 230 V mains

3.2.1.1 Radio interference suppression

Required radio interference suppression measures for a switching frequency of 8 kHz and shielded, low-capacitance motor cable, shield is not interrupted.

8200 vector		Measure for RFI level							
Type	Power [kW]	"A" for motor cable length				"B" for motor cable length			
		up to 10 m	10 ... 20 m	20 ... 50 m	50 ... 100 m	up to 10 m	10 ... 20 m	20 ... 50 m	50 ... 100 m
E82EV251K2Cxxx	0.25	C000	C000	C200 + LD	C200 + LD + MF	C000	C200 + SD	C200 + LD	C200 + LD + MF
E82EV371K2Cxxx	0.37								
E82EV551K2Cxxx	0.55	C000	C000	C200 + LD	C200 + LD + MF	C200 + SD	C200 + SD	C200 + LD	C200 + LD + MF
E82EV751K2Cxxx	0.75								
E82EV152K2Cxxx	1.5								
E82EV222K2Cxxx 1)	2.2								
E82EV302K2Cxxx	3.0								
E82EV402K2Cxxx	4.0								
E82EV552K2Cxxx	5.5	C000	C200 + SD	C200 + LD	C200 + LD + MF	C200 + SD	C200 + SD	C200 + LD	C200 + LD + MF
E82EV752K2Cxxx	7.5	C000 + N	C200 + SD + N	C200 + LD + N	C200 + LD + MF + N	C200 + SD + N	C200 + SD + N	C200 + LD + N	C200 + LD + MF + N

- C000 8200 vector with integrated RFI filter
- C200 8200 vector without integrated RFI filter
- + SD RFI filter "SD" is required in addition
- + LD RFI filter "LD" is required in addition
- + MF Motor filter is required in addition
- + N Mains choke is required in addition
- 1) A 2-pole supply additionally requires a mains choke

Assignment table of footprint RFI filter, motor filter and mains choke

Type	8200 vector		Footprint RFI filter		Motor filter Order No.	Mains choke Order No.
	Mains voltage [V]	Power [kW]	Order No. type "SD"	Order No. type "LD"		
E82EV251K2C200	1/N/PE AC 230 V	0.25	E82ZZ37112B200	E82ZZ37112B210	E82ZM22232B	ELN1-0900H005
E82EV371K2C200		0.37				
E82EV551K2C200		0.55	E82ZZ75112B200	E82ZZ75112B210		ELN1-0900H009
E82EV751K2C200		0.75				
E82EV152K2C200		1.5	E82ZZ22212B200	E82ZZ22212B210		E82ZL22212B
E82EV222K2C200		2.2				
E82EV551K2C200	3/PE AC 230 V	0.55	E82ZZ75132B200	E82ZZ75132B210	E82ZM22232B	E82ZL75132B
E82EV751K2C200		0.75				
E82EV152K2C200		1.5	E82ZZ22232B200	E82ZZ22232B210		E82ZL22232B
E82EV222K2C200		2.2				
E82EV302K2C200		3.0	E82ZZ40232B200 2)	82ZZ40232B210 2)	in preparation	ELN3-0120H017
E82EV402K2C200		4.0				
E82EV552K2C200		5.5	E82ZZ75232B200 2)	E82ZZ75232B210 2)		ELN3-0120H025 ELN3-0088H035 1)
E82EV752K2C200		7.5				

- 1) Operation with increased rated power
- 2) Still not available

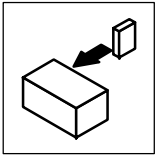

Wiring according to EMC

Power connections

Wiring of the motor filter 230 V

- Install the motor filter next to the controller in such a way that the connecting cable is as short as possible:
 - up to 200 mm the cable does not have to be shielded.
 - from 200 mm a shielded cable must be used.
- The cable from the motor filter to the motor is subject to the same rules as for the motor cable.

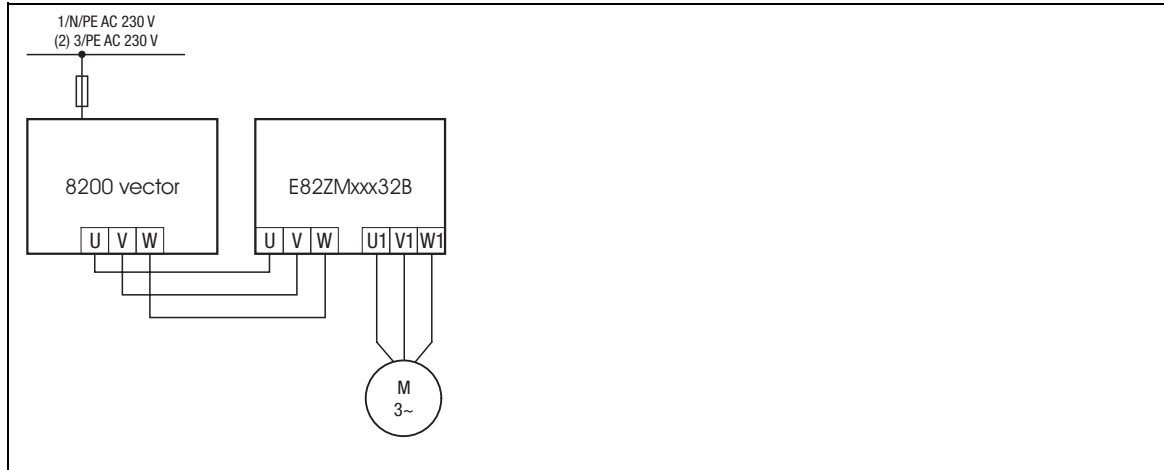

Fig. 4

Wiring of the motor filter 230 V



Fig. 5

Mounting example of frequency inverter with motor filter

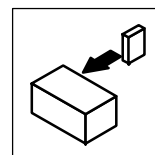

3.2.1.2 Limitation of harmonic currents

For complying with the limit values according to EN 61000-3-2 the following measures must be taken for the 8200 vector frequency inverters. Please observe that the radio interference suppression measures already mentioned must be taken in addition.

Essential measures for complying with the limit values according to EN 61000-3-2

Type	8200 vector		Measure
	Mains voltage [V]	Power [kW]	
E82EV251K2Cxxx	1/N/PE AC 230 V	0.25	C000 + N
E82EV371K2Cxxx		0.37	C200 + N
E82EV551K2Cxxx		0.55	C000 + AF C200 + AF
E82EV751K2Cxxx		0.75	
E82EV551K2Cxxx	3/PE AC 230 V	0.55	C000 + N C200 + N
E82EV751K2Cxxx		0.75	

C000 8200 vector with integrated RFI filter
 C200 8200 vector without integrated RFI filter
 + N Mains choke is required in addition
 + AF Active filter is required in addition (on demand)

Assignment table of mains chokes and active filters

Type	8200 vector		Mains choke Order No.	Active filter
	Mains voltage [V]	Power [kW]		
E82EV251K2Cxxx	1/N/PE AC 230 V	0.25	ELN1-0900H005	—
E82EV371K2Cxxx		0.37		
E82EV551K2Cxxx		0.55	—	on request
E82EV751K2Cxxx		0.75		
E82EV551K2Cxxx	3/PE AC 230 V	0.55	E82ZL75132B	—
E82EV751K2Cxxx		0.75		

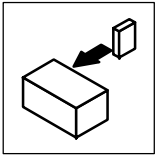

Wiring according to EMC

Power connections

3.2.2 400 V mains

3.2.2.1 Radio interference suppression

Required radio interference suppression measures for a switching frequency of 8 kHz and shielded, low-capacitance motor cable, shield is not interrupted.

8200 vector		Measure for RFI level							
Type	Power [kW]	"A" for motor cable length				"B" for motor cable length			
		up to 10 m	10 ... 20 m	20 ... 50 m	50 ... 100 m	up to 10 m	10 ... 20 m	20 ... 50 m	50 ... 100 m
E82EV551K4Cxxx	0.55	C000	C000	C200	C200	C000	C200 + SD	C200 + LD	C200
E82EV751K4Cxxx	0.75			+ LD	+ LD + MF				+ LD + MF
E82EV152K4Cxxx	1.5	C000	C000	C200	C200	C200 + SD	C200 + SD	C200 + LD	C200
E82EV222K4Cxxx	2.2			+ LD	+ LD + MF				+ LD + MF
E82EV302K4Cxxx	3.0	C000	C200 + SD	C200	C200	C200 + SD	C200 + SD	C200 + LD	C200
E82EV402K4Cxxx	4.0			+ LD	+ LD + MF				+ LD + MF
E82EV552K4Cxxx	5.5			+ LD	+ LD + MF				+ LD + MF
E82EV752K4Cxxx	7.5	C200 + SD	C200 + SD	C200 + LD	C200 + LD + MF	C200 + SD	C200 + SD	C200 + LD	C200 + LD + MF
E82EV113K4Cxxx	11	C200 + SD + N	C200 + SD + N	C200 + LD + N	C200 + LD + MF + N	C200 + SD + N	C200 + SD + N	C200 + LD + N	C200 + LD + MF + N

- C000 8200 vector with integrated RFI filter
- C200 8200 vector without integrated RFI filter
- + SD RFI filter "SD" is required in addition
- + LD RFI filter "LD" is required in addition
- + MF Motor filter is required in addition
- + N Mains choke is required in addition

Assignment table of footprint RFI filter, motor filter and mains choke

Type	8200 vector		Footprint RFI filter		Motor filter Order No.	Mains choke Order No.
	Mains voltage [V]	Power [kW]	Order No. type "SD"	Order No. type "LD"		
E82EV551K4C200	3/PE AC 400 V	0.55	E82ZZ75134B200	E82ZZ75134B210	E82ZM75134B	EZN3A1500H003
E82EV751K4C200		0.75				
E82EV152K4C200		1.5	E82ZZ22234B200	E82ZZ22234B210	E82ZM22234B020	E82ZL22234B
E82EV222K4C200		2.2				
E82EV302K4C200		3.0	E82ZZ55234B200	E82ZZ55234B210	E82ZM40234B	EZN3A0500H007
E82EV402K4C200		4.0				EZN3A0300H013 ¹⁾
E82EV552K4C200		5.5				EZN3A0300H013
E82EV752K4C200		7.5	E82ZZ11334B200	E82ZZ11334B210	E82ZM75234B	ELN3-0120H017
E82EV113K4C200		11.0	E82ZZ11334B200	E82ZZ11334B210	E82ZM11334B	ELN3-0150H024 ¹⁾

¹⁾ Operation with increased rated power

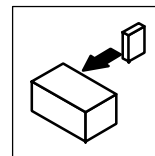

Wiring of the motor filter 400 V

- Install the motor filter so that the cable length does not exceed 200 m:
 - This cable does not have to be shielded.
- The cable from the motor filter to the motor is subject to the same rules as for the motor cable.



Note!

The connections +UG and -UG of the motor filter must be directly connected with the connections +UG and -UG of the controller (no fuses in the connecting cable)! Otherwise the motor filter can be destroyed.

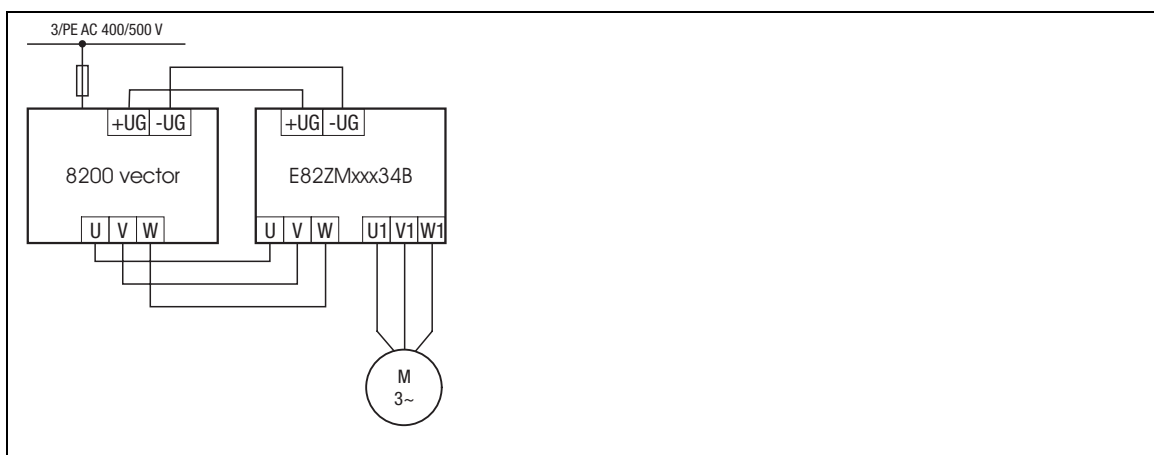

Fig. 6

Wiring of the motor filter 400 V

3.2.2.2 Limitation of harmonic currents

For complying with the limit values according to EN 61000-3-2 the following measures must be taken for the 8200 vector frequency inverters. Please observe that the radio interference suppression measures already mentioned must be taken in addition.

Essential measures for complying with the limit values according to EN 61000-3-2

Type	8200 vector		Measure
	Mains voltage [V]	Power [kW]	
E82EV551K4Cxxx	3/PE	0.55	C000 + N C200 + N
E82EV751K4Cxxx	AC 400 V	0.75	

C000 8200 vector with integrated RFI filter
 C200 8200 vector without integrated RFI filter
 + N Mains choke is required in addition

Assignment table of mains chokes

Type	8200 vector		Mains choke Order No.
	Mains voltage [V]	Power [kW]	
E82EV551K4Cxxx	3/PE	0.55	E82ZN3A1500H003
E82EV751K4Cxxx	AC 400 V	0.75	

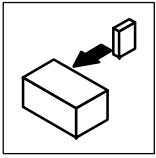

Wiring according to EMC

Control connections

3.3 Control connections

This chapter describes the wiring according to EMC of the analog and digital control connections of the function modules Standard I/O and Application I/O.

The wiring according to EMC with bus function modules is described in separate publications.

3.3.1 Basic rules for wiring

Complying with the specifications of the control cables

- The cables of the analog and digital inputs and outputs must be shielded. If short (up to 200 mm) and unshielded cables are used, they must be twisted.

Connect the shield of the control cables correctly.

- Continue the shield after the shield clamp to the terminals. Do not exceed an unshielded cable length of 40 mm.
- In case of the analog cables the shield must only be connected to the controller.
- In unfavorable conditions (very long cable, high interferences) it is possible in case of analog cables to connect one shield end to PE via a capacitor (e.g. 10 nF/250 V) to have a better shielding effect (see sketch).

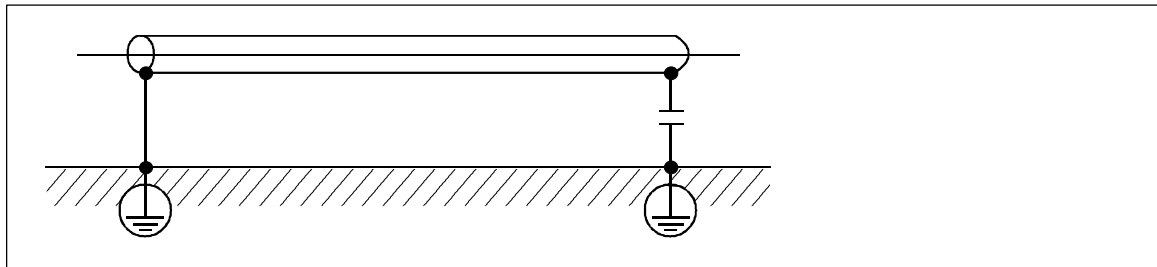
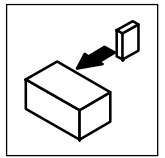

Fig. 7

Shielding of long, analog control cables

- In case of digital cables the shield must be connected on both sides.
- Further shield connection points (e.g. at terminal strips) must be selected with a minimum distance of 50 mm to the shield connections of motor cables and DC cables.



3.4 Relay output

This chapter describes the wiring according to EMC of the relay output. With the relay output the controller switches control signals and mains potentials. Information on the switching capacity is given in the Technical Data of the basic device.

3.4.1 Basic rules for wiring

- For switching the control signals the rules for the wiring of control connections apply (see chapter 3.3.1).
- For switching the mains potentials wiring with unshielded cables is sufficient.

3.4.2 Wiring

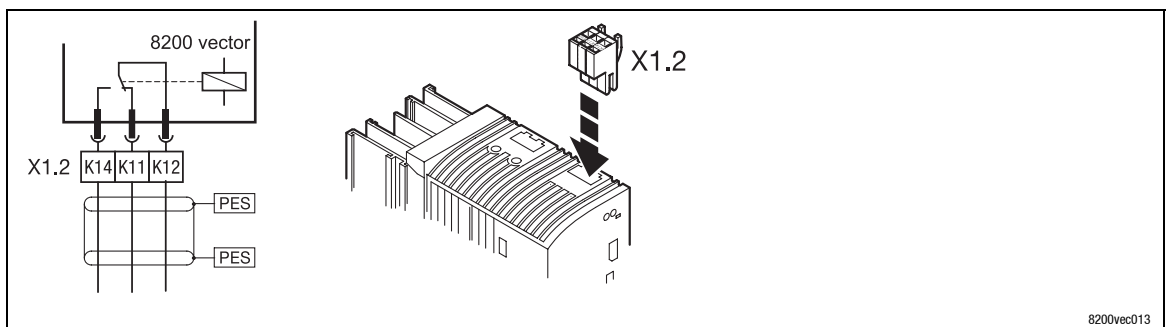
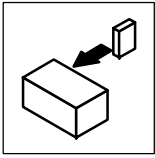

Fig. 8

Wiring of relay output

	Function	Relay position set	Message (Lenze setting)
X1.2/K11	Relay output NC contact	open	TRIP
X1.2/K12	Relay middle contact		
X1.2/K14	Relay output NO contact	closed	TRIP
PES	HF-shield end by PE connection through shield clamp.		



Wiring according to EMC

PTC input

3.5 PTC input

The terminals T1, T2 are input terminals for connecting the PTC thermistors acc. to DIN 44081 and DIN 44082. These serve to detect the motor temperature and integrate it into the drive monitoring.

3.5.1 Basic rules for wiring

The EMC safety of the PTC input depends on the laying system of the shielded cable.

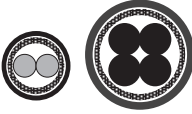
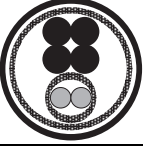
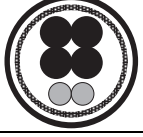
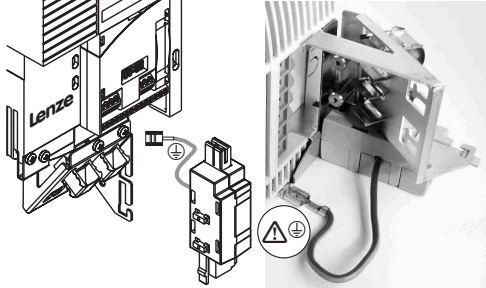
EMC safety	Type of laying	Note
Very good	Motor cable and PTC/thermal contact cable are laid separately 	Ideal laying system with very low interference injections. Connect the shielding of the PTC / thermal contact cable with shield clamps to the EMC shield sheet with a large contact surface.
Medium	Motor cable and PTC/thermal contact cable are laid together with separate shields 	Laying system is permitted but shows higher interference injections. Connect the shielding of the PTC / thermal contact cable with shield clamps to the EMC shield sheet with a large contact surface.
Unfavorable	Motor cable and PTC/thermal contact cable are laid together with a common shield  	High-energy interference injections! Laying system is only permitted if the EMC kit E82ZPEX is used additionally!

3.5.2 Wiring

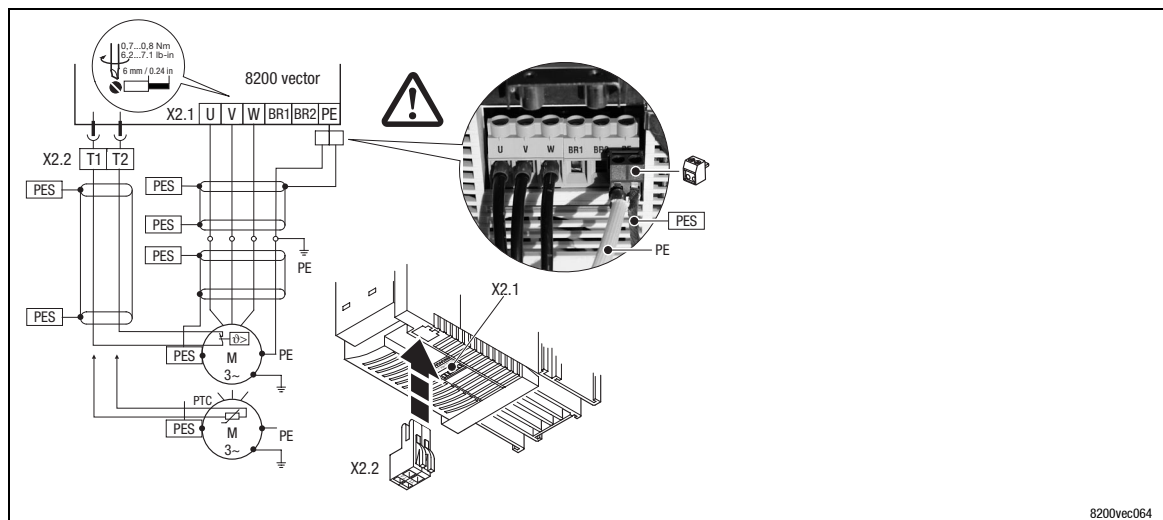
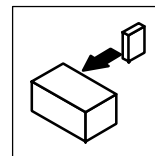

Fig. 9 Wiring of PTC input



3.6 Accessories

3.6.1 Mains choke

A mains choke is an inductor which can be connected into the mains cable of the frequency inverter. Mains chokes can be used together with RFI filter and / or motor filters.

The mains choke has the following functions:

- Reducing system perturbations
 - The curved shape of the mains current is approached to the sinusoidal shape.
- Reducing the mains current
 - Reducing the effective mains current (i.e. reducing the mains, cable, and fuse load).
- Improving the service life of the 8200 vector
 - Reducing the AC current load on the electrolytic capacitors in the DC bus serves to prolong their service life.



Note!

- Some 8200 vector frequency inverters must always be operated with a mains choke, independent of EMC measures.
- When operating with a mains choke the maximum motor voltage does not reach the value of the mains voltage - typical voltage drop at rated frequency and rated device current: 6 %.

3.6.1.1 Basic rules for wiring

- The mains choke is wired via single cores to the mains.
- The cable cross-section must be rated for the assigned fuse protection (EN 50178).

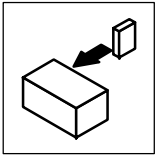

Wiring according to EMC

Accessories

3.6.2 Brake resistor

Brake resistors can be connected to the terminals BR1 / BR2. This enables an undisturbed braking operation (operation in generator mode)

3.6.2.1 Basic rules for wiring

- Only use shielded cables for the brake resistor.
- Connect the shield to the EMC shield sheet of the controller.
- Connect the shield near the brake resistor to the mounting plate with a large contact surface using a shield clamp.
- Connect the shield of the control cables for digital signals (temperature monitoring T1 / T2) on both sides - controller and brake resistor.
- Continue the shield after the shield clamp to the terminals. Do not exceed an unshielded cable length of 40 mm.
- The maximum cable length amounts to 8 m.

3.6.2.2 Wiring

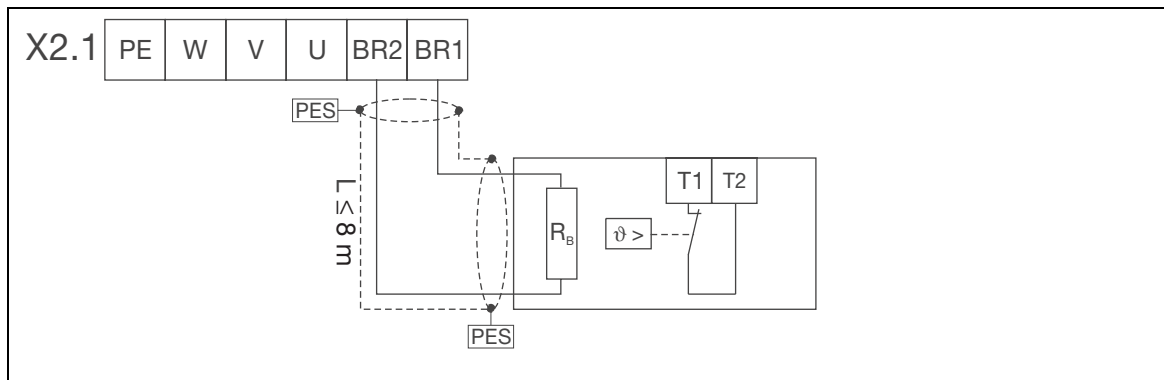
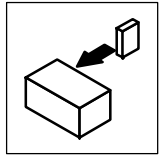

Fig. 10 Wiring of brake resistor

PES HF-shield end by PE connection through shield clamp.



3.6.3 DC-bus system

In the DC bus system connected controllers exchange energy on the DC voltage level.

3.6.3.1 Basic rules for wiring

- Shield the cables between the controller (+UG / -UG) and the supply busbar.
- Connect the shield on both sides to the mounting plate with a large contact surface.
- Keep the cables as short as possible.
- Install the cables close to each other to avoid loops which may produce magnetic fields.
- Cable lengths up to 100 mm do not have to be shielded (if possible, twist them).

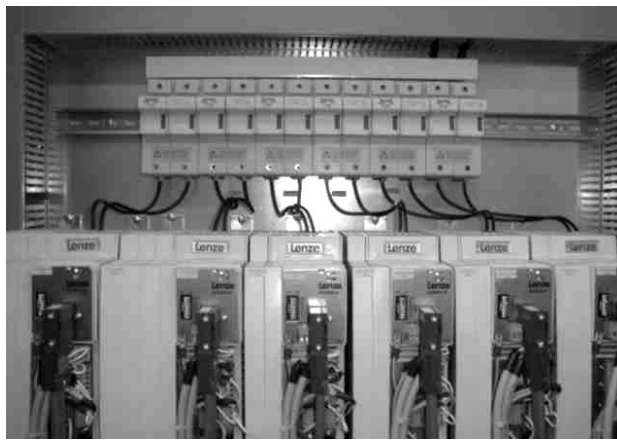

Fig. 11

Example for DC-bus operation



Recognising and eliminating EMC interferences

4 Recognising and eliminating EMC interferences

Interference	Cause	Remedy
Interferences of analog setpoints of the own or other devices and measuring systems	Unshielded motor cable	Use a suitable cable: <ul style="list-style-type: none"> • Use a shielded motor cable
	EMC shield sheet with shield clamps has not been used	Optimise shielding of the motor cable: <ul style="list-style-type: none"> • Optimise shielding according to Instructions
	Motor cable shield is interrupted by terminals, switches etc.	Optimise the arrangement: <ul style="list-style-type: none"> • Spatially separate the components from other parts with a distance of at least 100 mm • Insert motor interference suppression module
	Additional, unshielded cables are installed within the motor cable (e.g. temperature monitoring)	Optimise wiring: <ul style="list-style-type: none"> • Separate and shield additional cables • Use EMC kit E82ZPEX
	Unshielded connection ends of the motor cable are too long	Optimise wiring: <ul style="list-style-type: none"> • Shorten unshielded cable ends to maximally 40 mm
Conducted interference level is exceeded on the mains side	Filter measures on the mains side are not sufficient	Optimise interference suppression: <ul style="list-style-type: none"> • Use additional RFI filters acc. to table (☞ 15 ff)
	Motor cable capacitance is too high	Optimise motor cable: <ul style="list-style-type: none"> • Use low-capacitance motor cables!
	Motor cable terminals are directly mounted beside the supply terminals	Optimise wiring: <ul style="list-style-type: none"> • Spatially separate motor cable terminals from the supply terminals and other control terminals with a distance of at least 100 mm
	Mounting plate in the control cabinet is varnished	Optimise PE connection: <ul style="list-style-type: none"> • Carefully remove the varnish • Use zinc-coated mounting plate
	HF short circuit	Check installation: <ul style="list-style-type: none"> • Cable routing

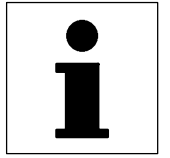



Notes

